



# CARING FOR KNITWEAR

## *Techniques for Folding*

### PULLOVERS & CARDIGANS

#### *Step 1*

Lay your sweater flat with the front facing down

#### *Step 2*

Fold the sides in so they meet at the center

#### *Step 3*

Tuck the sleeves in

#### *Step 4*

Fold the hem up to meet the neckline

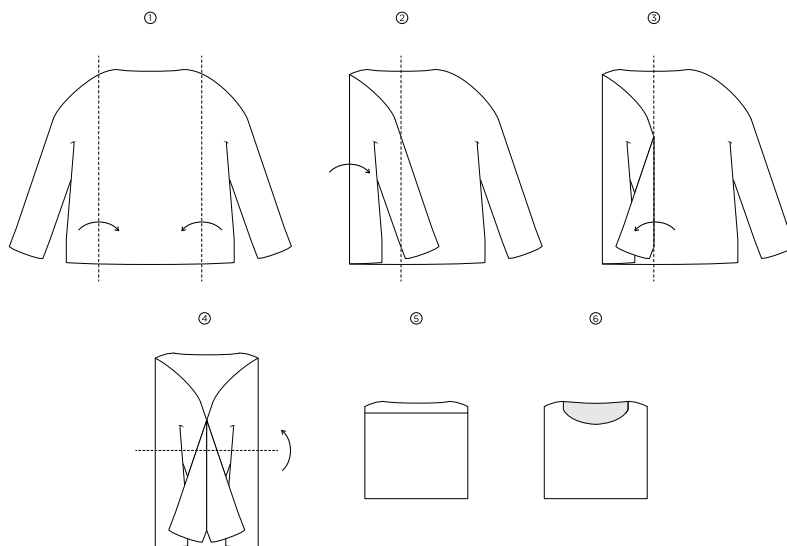

### SHAWLS

#### *Step 1*

Fold in half along the top edge

#### *Step 2*

Fold diagonally so the top meets the center of the shawl

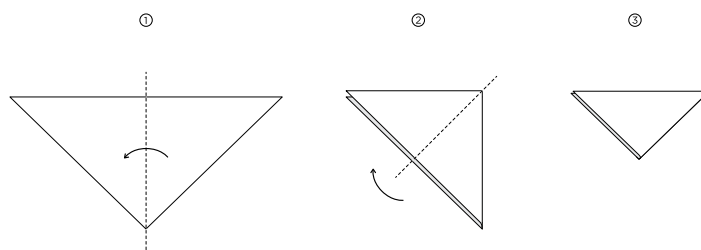

### SCARVES & WRAPS

#### *Step 1*

Fold top edges to meet in the center

#### *Step 2*

Fold in half again so the folded edges meet

